

APPLICATION

- ▶ Suitable for residential or light commercial folding partitions.
- ▶ Leaves are hung centrally under the lintel and can fold to one or both sides of the opening.
- ▶ To cover any width of opening, any number of folding units can be used.

DOOR SPECIFICATION

Track System:	Centrefold 45	Centrefold 75
For Individual Leaves:		
Max Leaf Height	3000mm	3300mm
Max Leaf Weight	45kg	75kg
Max Leaf Width	920mm	920mm
Min Leaf Thickness	35mm	44mm

Folding units of up to seven full leaves and one half leaf can be hinged to a post.

Floating units consist of five, seven or nine full leaves.

Access should be through either a separate door hinged to a post or a door hinged in one of the folding leaves.

Instruction on leaf width calculation is shown overleaf.

Clearance between leaves to be 2mm minimum.

Door leaves should be constructed to provide secure fitting for hangers, hinges and guides and can be flush, panelled or glazed.

HARDWARE SPECIFICATION

Track:	180	250
Material	Aluminium	Aluminium
Standard lengths	2000mm, 3000mm, 4000mm and 6000mm	

Bracket:

Bracket 316 Stainless Steel	ISS/250	ISS/250
-----------------------------	---------	---------

Fit at 900mm maximum centres.

Fit additional bracket where folding units stack and at the ends of the track.

Hanger:	61/4GN	61/4HN
----------------	--------	--------

Hangers are fitted with nylon tyre wheels on ball race bearings.

Vertical adjustment is simple and positive.

Guide:	106RB/94	106RB/94
---------------	----------	----------

Guide incorporates a precision bearing.

All steel parts to hangers and guides are stainless steel.

Hinge:

Butt hinge	404/2	404/3
------------	-------	-------

404/2: 85x60, 404/3: 100x75

Channels:

Aluminium	94A	94A
Brass	94B	94B

Standard lengths 2000mm, 3000mm, 4000mm and 6000mm
Drilled and countersunk for screwing to timber floor or attaching to lugs 94L when installing in concrete floor.

94PA used to support 94P channel, 94P not to be used on its own.

Accessories: Flush Pulls and Flush Bolts.

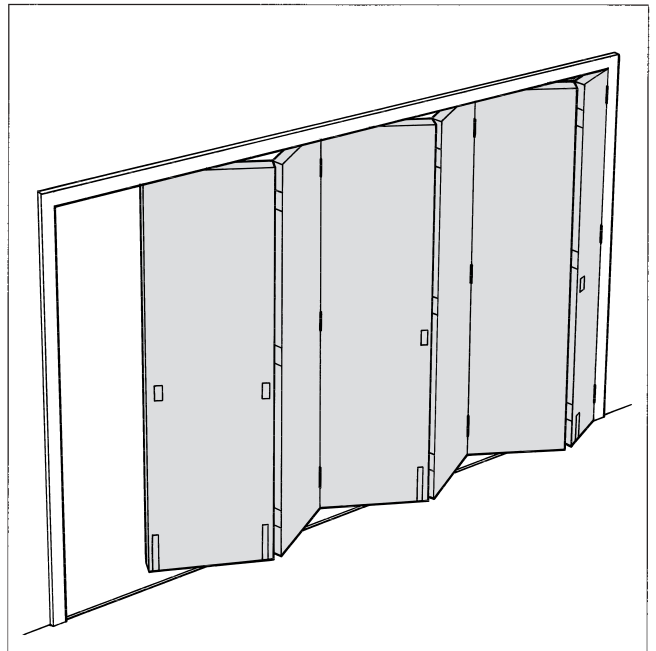

No. 61/4 Hanger

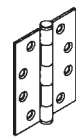

Butt Hinge

No. 404/3S Satin Chrome
No. 403/3B Polished Brass
No. 404/2S Satin Chrome

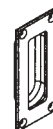

No.400 Flush Pull.
108 x 48 with 17 mortice.
Available insatin anodised aluminium or in polished brass or satin chrome on brass.

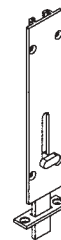

Flush Bolt - 190 x 41
with 10 mortice

No. 456A - S.A.A.
No. 456S - Satin Chrome
No. 456B - Polished Brass
No. 456C - Polished Chrome

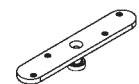

No. 106RB/94
Guide

Centrefold 45 & 75

FOR TOP HUNG INTERIOR FOLDING PARTITIONS, MAX. 75kg EACH LEAF

HENDERSON®

SLIDING & FOLDING DOOR HARDWARE

AUSTRALIA'S WIDEST RANGE

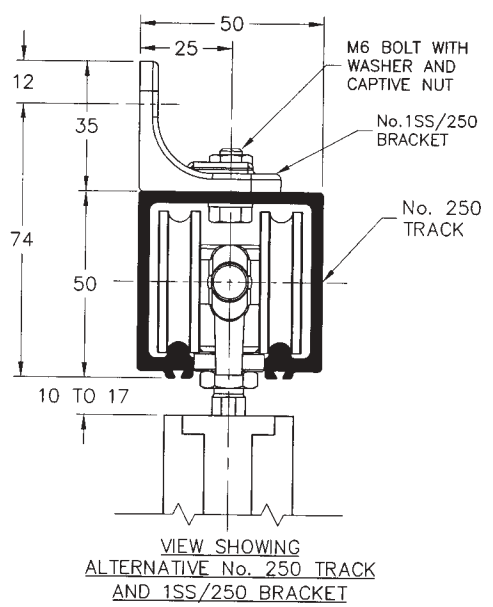
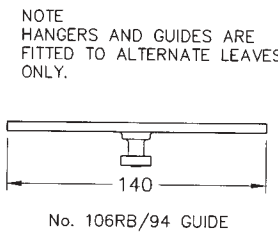
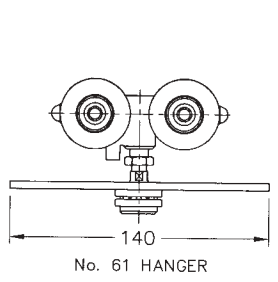
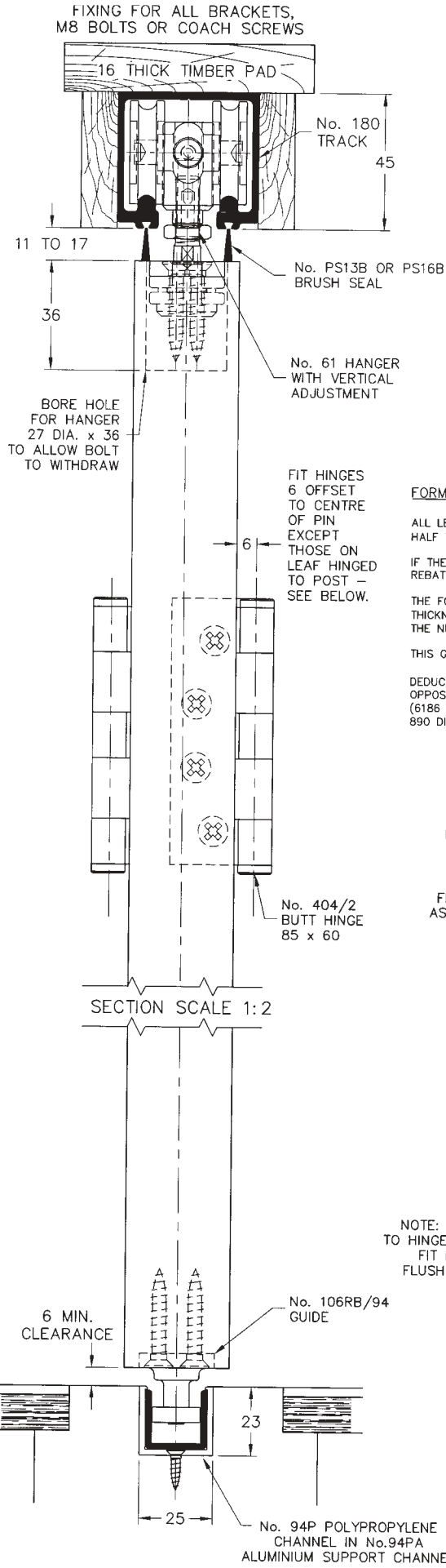

NOTE
HANGERS AND GUIDES ARE
FITTED TO ALTERNATE LEAVES
ONLY.

FORMULA FOR LEAF WIDTH CALCULATIONS

ALL LEAVES ARE THE SAME WIDTH, HINGE PIN TO HINGE PIN CENTRES. EXCEPT A LEAF HINGED TO A POST, WHICH MUST BE HALF THE WIDTH OF A FULL LEAF LESS HALF THE LEAF THICKNESS.

IF THE STILES ARE BEING REBATED, THE LEAVES WILL HAVE TO BE MADE WIDER THAN CALCULATED TO ALLOW FOR THE REBATING.

THE FORMULA FOR CALCULATING THE WIDTH OF LEAVES FOR A PARTITION 44 THICK IS AS FOLLOWS - ADD 22 (HALF LEAF THICKNESS) TO THE WIDTH BETWEEN THE REBATED POSTS FOR EACH LEAF HINGED TO A POST AND DIVIDE THE RESULT BY THE NUMBER OF LEAVES. I.E. FOR THREE AND A HALF LEAVES, DIVIDE BY 3.5.

THIS GIVES THE WIDTH OF THE FULL LEAVES. THE LEAF HINGED TO THE POST IS HALF THE THE FULL LEAF WIDTH LESS 22.

DEDUCT 2 FROM EACH MEASUREMENT FOR CLEARANCES. FOR EXAMPLE, 2 UNITS OF 3½ LEAVES 44 THICK, EACH HINGED TO OPPOSITE POSTS, WITH 6186 OVERALL BETWEEN POSTS -
 $(6186 + 22 + 22) / 7 = 890$ LESS 2 = 888 FOR WIDTH OF WIDER LEAVES.
 890 DIVIDED BY 2 = 445 LESS 22 LESS 2 = 421 FOR WIDTH OF LEAVES HINGED TO POSTS.

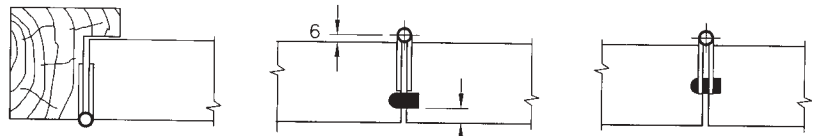

FIT BUTT HINGES TO POST AS SHOWN WITH NO OFFSET

OFFSET OF TONGUE, GROOVE AND BUTT HINGES, AVOIDS THE CUTTING OF TONGUES

CENTRAL TONGUES MUST BE CUT AROUND BUTT HINGES



PLAN 1
5½ LEAVES HINGED TO POST AS PLAN 1

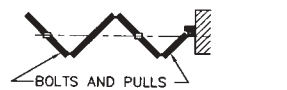

PLAN 2
3½ LEAVES HINGED TO POST AS PLAN 2

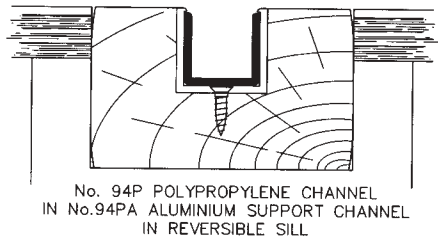
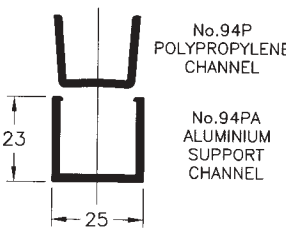
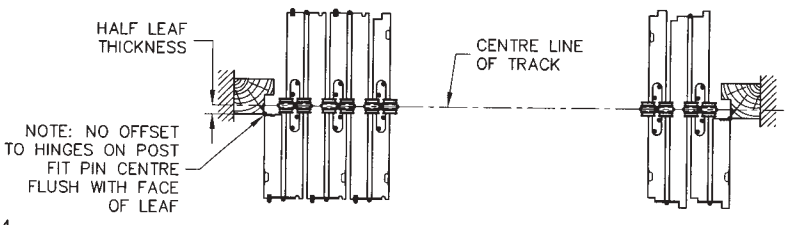

HENDERSON RMD

Door Hardware Division of
RMD PRESS CO. PTY LTD.

ACN 004 313 937

© COPYRIGHT HENDERSON RMD

© HENDERSON IS A REGISTERED TRADEMARK OF PC HENDERSON LTD (UK)



SALES OFFICES IN ALL STATES

D160B