

Double Run 700

FOR TOP HUNG STRAIGHT SLIDING DOORS, MAX. 700kg EACH

HENDERSON®

SLIDING & FOLDING DOOR HARDWARE

AUSTRALIA'S WIDEST RANGE

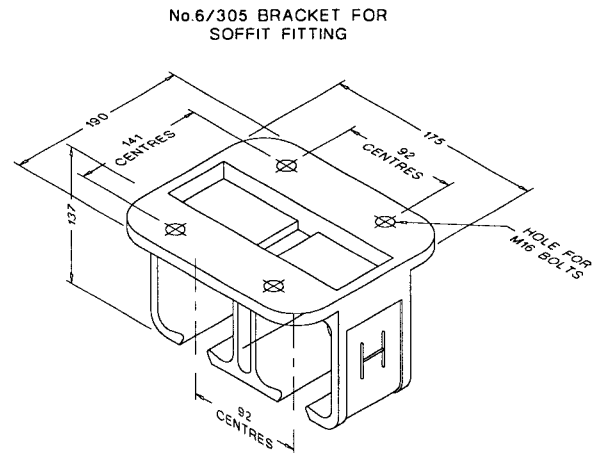
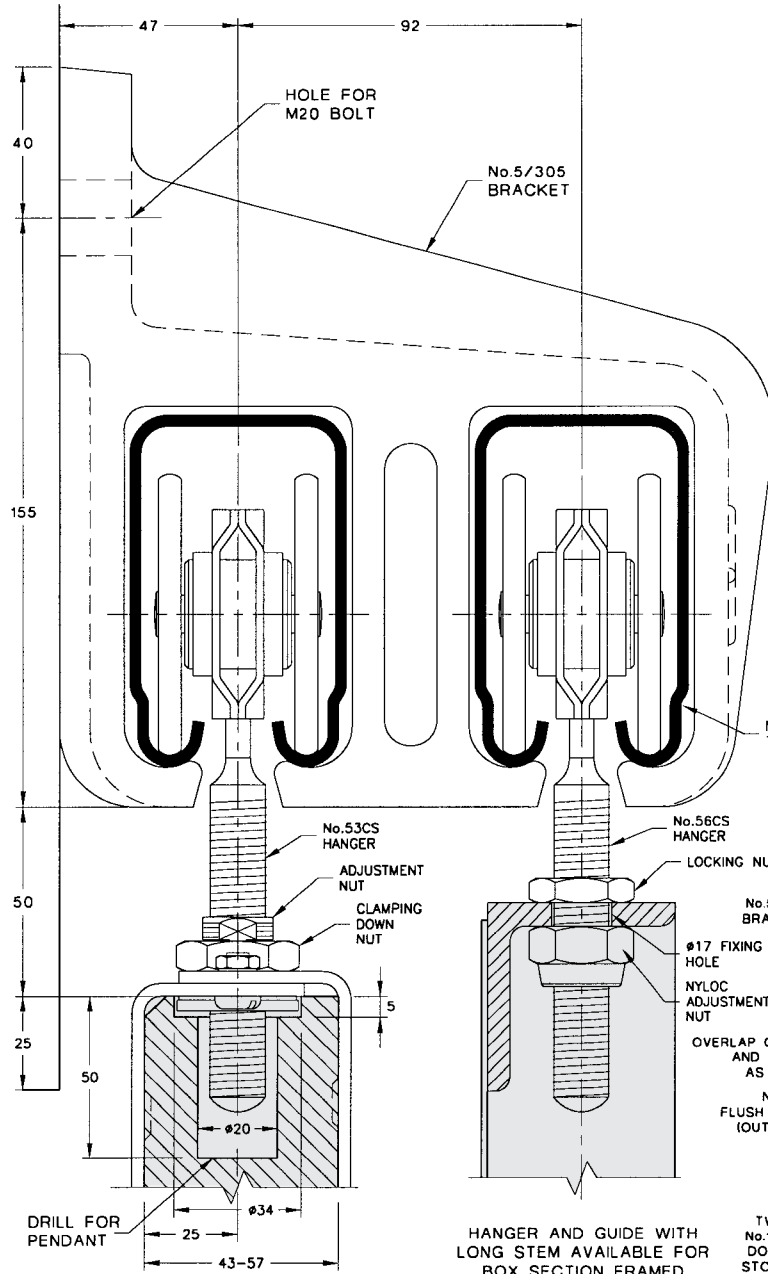

STANDARD TRACK LENGTH	2000	3000	4000
NORMAL BRACKET CENTRES	650-700	750	800

FOR HEAVY DOORS, OR THOSE SUBJECTED TO ABNORMAL USE, BRACKET CENTRES SHOULD BE REDUCED TO 500

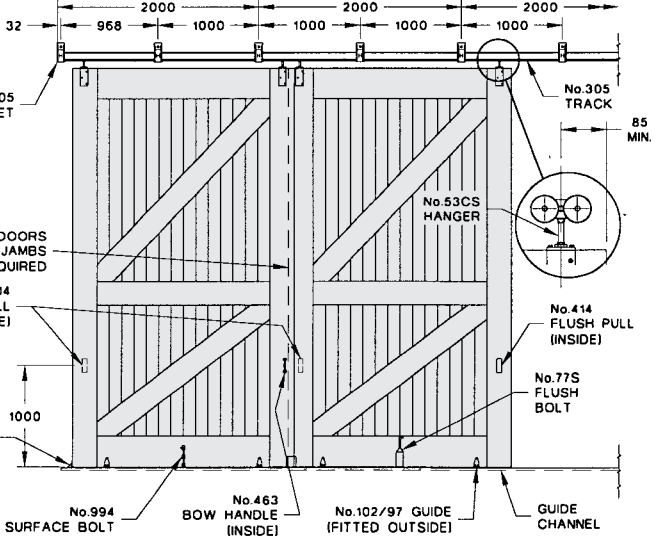
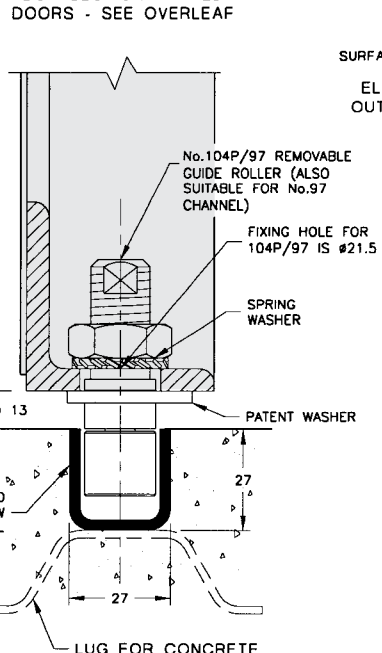
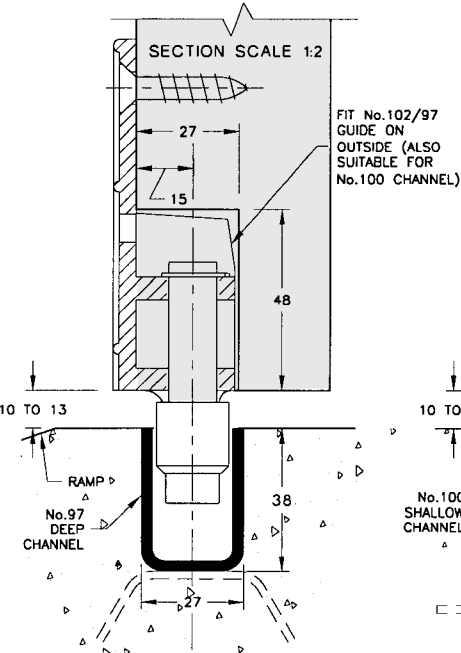

ELEVATION - DOORS SLIDING INSIDE IF DOORS SLIDING ON OUTSIDE, REPLACE SURFACE BOLT WITH No. 77S FLUSH BOLT AND BOW HANDLE WITH No. 414 FLUSH PULL.

